



STRENGTH LINE

SALTER
The essence of fitness

SALTER, EQUIPAMIENTO COMPLETO PARA TU INSTALACIÓN

Trabajamos para aportar toda nuestra experiencia a cada proyecto con el objetivo de ofrecer la opción que mejor se adapta a las necesidades de cada cliente. Contamos para ello con una amplia gama de maquinaria fitness, cardio y de rehabilitación para el equipamiento completo de instalaciones y salas de fitness. Máxima calidad, atención y servicio al cliente son nuestras premisas. Trabajando de forma constante en el cumplimiento de estos valores **SALTER** se ha convertido en una marca de referencia en el sector.

SALTER, FULL EQUIPMENT FOR YOUR SPORTS FACILITIES

We work to bring all our experience to each project in order to offer the best solution to each client. We have a wide range of fitness, cardio and rehabilitation equipment to fully equip sport facilities and fitness rooms. Maximum quality, attention and customer service are our focus. By constantly working to fulfil these values, **SALTER** has become one of the main brands in the fitness sector.

SALTER, L'ÉQUIPEMENT COMPLET POUR VOTRE INSTALLATION

Nous travaillons pour apporter toute notre expérience à chaque projet dans le but d'offrir l'option qui s'adapte le mieux aux besoins de chaque client. Nous avons une large gamme de machines de musculation, de cardio et de rééducation pour l'équipement complet d'installations et salles de fitness. La qualité, l'attention et le service, ce sont nos principes. En travaillant à la réalisation de ces valeurs, **SALTER** s'est imposé comme une marque de référence dans le secteur.



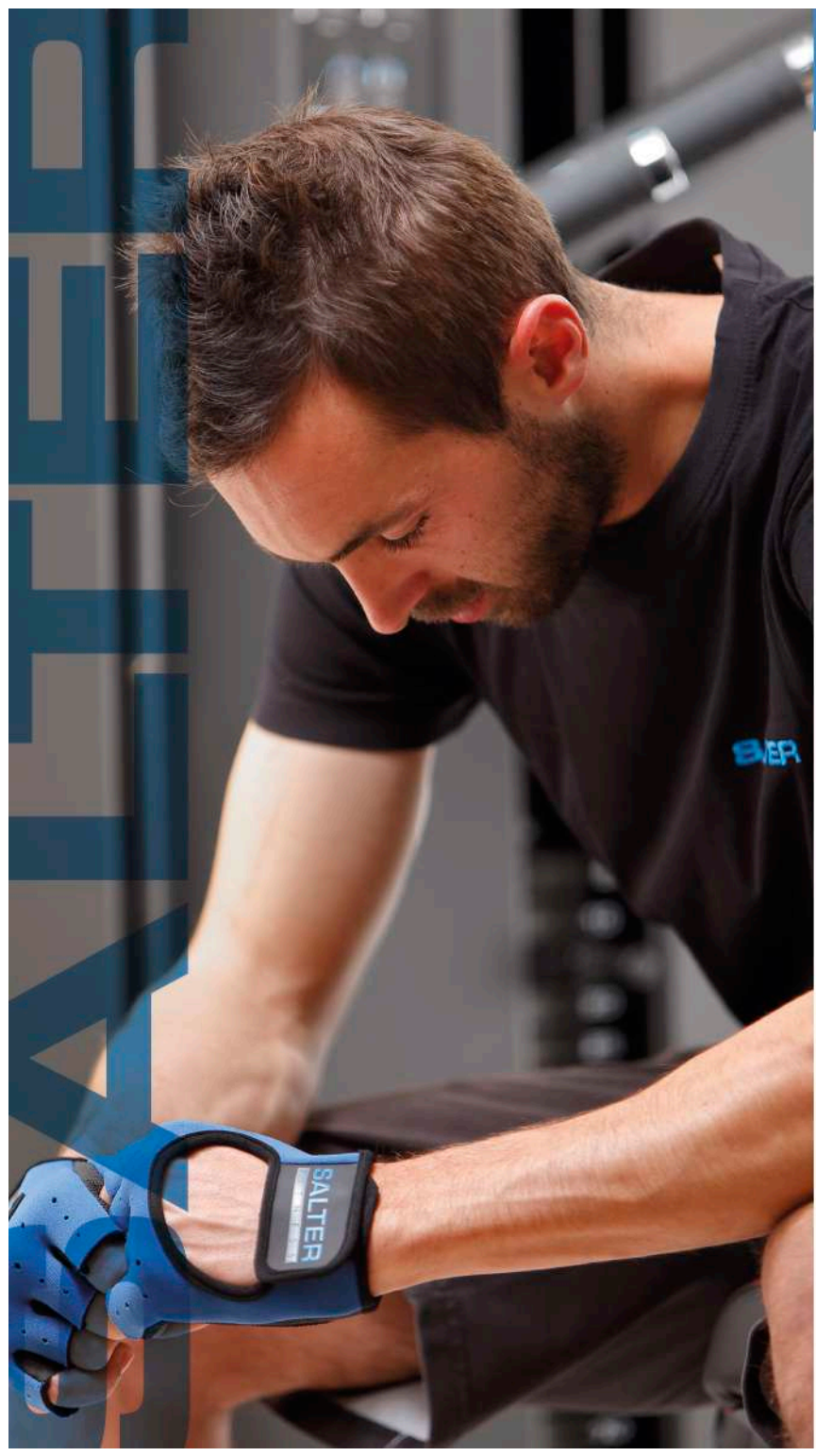

MÁQUINAS DE FUERZA LÍNEA ESSENCE

ESSENCE STRENGTH MACHINES · MACHINES DE MUSCULATION LIGNE ESSENCE **04**

MULTIPOLEAS

MULTIPLE PULLEYS · POULIES MULTIPLES **14**

ENTRENAMIENTO FUNCIONAL

FUNCTIONAL TRAINING · ENTRAÎNEMENT FONCTIONNEL **21**

MÁQUINAS DE PESO LIBRE

FREE WEIGHT MACHINES · MACHINES À POIDS LIBRE **25**

BANCOS

BENCHES · BANCS **33**

SOPORTES Y MANCUERNAS

RACKS AND DUMBBELLS · SUPPORTS ET HALTÈRES **38**

MÁQUINAS LÍNEA CIRCUIT

CIRCUIT LINE MACHINES · MACHINES LIGNE CIRCUIT **43**



Máquinas de fuerza Línea ESSENCE

ESSENCE STRENGTH MACHINES
MACHINES DE MUSCULATION LIGNE ESSENCE





■ ERGONOMÍA Y DISEÑO

La línea **ESSENCE** está compuesta por una completa línea de aparatos de tonificación muscular, bancos y soportes diseñados bajo las nuevas tendencias del fitness. Compactas, seguras, cómodas, fáciles de utilizar y con un diseño muy atractivo. Además, las máquinas **ESSENCE** han sido diseñadas biomecánicamente para un trabajo óptimo.



■ ERGONOMICS & DESIGN

The **ESSENCE** line is a full series of strength machines, benches and supports designed following new fitness trends. They are compact, safe, comfortable, easy to use and beautifully designed. Besides, **ESSENCE** machines have been biomechanically designed for optimal performance.

■ ERGONOMIE ET DESIGN

La ligne **ESSENCE** se compose d'une gamme complète d'appareils destinés à la tonification musculaire, des bancs et des supports conçus pour répondre aux nouvelles tendances en matière de fitness. Compacts, sûrs, confortables, faciles à utiliser et avec des lignes séduisantes. En outre, les machines **ESSENCE** ont été conçues de façon biomécanique, pour un travail optimum.

■ CARACTERÍSTICAS TÉCNICAS LÍNEA ESSENCE

- El chasis de las máquinas **ESSENCE** es de acero reforzado de 3 mm lo que proporciona una gran robustez y estabilidad.
- El acabado en pintura polvo poliéster a 200º de color negro mate ofrece gran calidad en el acabado.
- Los carenados termo-conformados, de color negro, pueden ser personalizados con el sistema de Personalización **ESSENCE** lo que permite que cada proyecto tenga su propia identidad y el diseño de las máquinas encaje con la decoración de la sala.
- El carenado va provisto de una bandeja porta-objetos en la parte superior.
- El cable de transmisión de 5 mm de grosor, sumamente flexible y resistente, se adapta perfectamente en todo el recorrido, evitando cualquier tipo de fricción durante la realización del ejercicio. Incorpora, además, tensor para facilitar el ajuste de la tensión.
- Las poleas de transmisión incorporan rodamientos a bolas que garantizan un movimiento suave y silencioso.
- Las máquinas disponen de múltiples ajustes y regulaciones para ajustar la posición de trabajo a las necesidades de cada usuario.
- El ajuste y regulación de los puntos de apoyo se realiza con pomos anatómicos fabricados en aluminio que garantizan una gran durabilidad.
- Los carriles de acero templado y con recirculación de bolas proporcionan una extrema precisión y suavidad en las regulaciones y en los desplazamientos lineales de los elementos a ajustar.
- Los agarres fabricados en material no poroso proporcionan un agarre cómodo y seguro a la vez que un alto nivel de confort.
- Las placas, provistas de casquillos de baja fricción para un movimiento más fluido, se deslizan sobre guías de acero inoxidable.
- El selector de placas incorpora sistema magnético de seguridad.
- Los niveladores regulables en la base garantizan una total estabilidad.



■ TECHNICAL CHARACTERISTICS ESSENCE

- The chassis of the **ESSENCE** machines is made of reinforced steel of 3 mm which provides great robustness and stability.
- The finish in polyester powder paint at 200° matt black color offers great quality in the finish.
- Thermoformed weight-stack case, in black color, can be customized with the **ESSENCE** Personalization system, which allows each project to have its own identity and the design of the machines to match the decoration of the room.
- The fairing is equipped with an object tray at the top.
- The 5 mm thick transmission cable, extremely flexible and resistant, adapts perfectly throughout the entire route, avoiding any type of friction during the exercise. It also incorporates a tensioner to facilitate the adjustment of the tension.
- The transmission pulleys incorporate ball bearings that guarantee a smooth and silent movement.
- The machines have multiple adjustments and regulations to set the work position to the needs of each user.
- The adjustment and regulation of the support points is made with anatomical knobs made of aluminum that guarantee great durability.
- The tempered steel and recirculating ball rails provide extreme precision and smoothness in the adjustments and in the linear displacements of the elements to be adjusted.
- The grips made of non-porous material provide a comfortable and secure grip while a high level of comfort.
- The plates, provided with low friction bushes for a more fluid movement, slide on stainless steel guides.
- The plate selector incorporates a magnetic safety system.
- Adjustable levelers in the base guarantee total stability.

■ CARACTÉRISTIQUES TECHNIQUES ESSENCE

- Le châssis des machines **ESSENCE** est en acier renforcé de 3 mm, ce qui assure une grande robustesse et stabilité.
- La finition en peinture en poudre polyester à 200° noir mat offre une grande qualité dans la finition.
- Les carénages thermoformés en noir peuvent système de Personnalisation **ESSENCE**, ce qui permet à chaque projet d'avoir sa propre identité et que l'image des machines puisse correspondre à la décoration de la salle.
- Le carénage est équipé avec un espace pour des objets personnels
- Le câble de transmission de 5 mm d'épaisseur, extrêmement flexible et résistant, s'adapte parfaitement tout au long du parcours, évitant tout type de frottement lors de l'exercice. Il intègre également un tendeur pour faciliter le réglage de la tension.
- Les poulies de transmission intègrent des roulements à billes qui garantissent un mouvement doux et silencieux.
- Les machines ont plusieurs ajustements et réglages pour ajuster la position de travail aux besoins de chaque utilisateur.
- Le réglage et la régulation des points d'appui sont élaborés avec des poignées anatomiques en aluminium qui garantissent une grande durabilité.
- Les rails en acier trempé et la circulation des billes apportent une précision et une fluidité extrêmes dans les réglages et dans les déplacements linéaires des éléments à régler.
- Les poignées en matériau non poreux offrent une adhérence confortable et sûr, en même temps qu'un haut niveau de confort.
- Les plaques, pourvus de douilles de basse friction pour un mouvement plus fluide, se glissent sur des guides en acier inoxydable.
- Le sélecteur des plaques incorpore un système de sécurité magnétique.
- Les niveleurs réglables dans la base garantissent une stabilité totale.

■ BELLEZA Y RESISTENCIA

- Los asientos anatómicos son sumamente amplios y confortables.
- La tapicería, resistente al uso intensivo, es antibacteriana, ignífuga y garantiza la ausencia de disolventes y sustancias nocivas.
- Las costuras en rojo intenso proporcionan vistosidad y gran acabado al conjunto.
- **SALTER** ofrece la posibilidad de personalizar la tapicería con la imagen corporativa o logotipo del cliente mediante un sistema de grabado por alta frecuencia que garantiza un perfecto acabado y durabilidad.

■ BEAUTY AND RESISTANCE

- The anatomical seats are extremely spacious and comfortable.
- The upholstery, resistant to intensive use, is antibacterial, flame retardant and guarantees the absence of solvents and harmful substances.
- The deep red seams provide eye-catching and great finishing to the set.
- **SALTER** offers the possibility to customize the upholstery with the corporate image or the customer logo through a system of engraving by high frequency that guarantees a perfect finish and durability.

■ BEAUTÉ ET RÉSISTANCE

- Les sièges anatomiques sont extrêmement spacieux et confortables.
- La sellerie, résistante à l'usage intensif, est antibactérienne, ignifuge et garantit l'absence de solvants et de substances nocives.
- Les coutures en rouge foncé procurent une superbe finition à l'ensemble.
- **SALTER** offre la possibilité de personnaliser la sellerie avec l'image corporative ou le logo de l'entreprise ou de client à travers un système de gravure par haute fréquence qui garantit une finition et une durabilité parfaites.



SISTEMA DE PERSONALIZACIÓN ESSENCE

ESSENCE PERSONALIZATION SYSTEM

SYSTÈME DE PERSONNALISATION D'ESSENCE

SALTER ofrece a sus clientes el servicio de personalización **ESSENCE** desarrollando un proyecto conceptual con un diseño único y exclusivo de las carcasas.

Utilizando una imagen, el logotipo o desarrollando un diseño conceptual único y exclusivo conseguimos que cada instalación tenga identidad propia. Además, con este sistema podemos lograr que las máquinas **ESSENCE** sean un elemento decorativo y queden totalmente integradas en el diseño de la sala consiguiendo un gran efecto visual.

SALTER offers its clients the **ESSENCE** customization service, developing a conceptual project with a unique and exclusive design of the casings.

Using an image, the logo or developing a unique and exclusive conceptual design, we ensure that each installation has its own identity. In addition, with this system we can make **ESSENCE** machines a decorative element and are fully integrated into the design of the room, achieving a great visual effect.

SALTER propose à ses clients le service de personnalisation **ESSENCE** développant un projet conceptuel avec un design unique et exclusif des boîtiers.

En utilisant une image, le logo ou en développant un design conceptuel unique et exclusif, nous veillons à ce que chaque installation ait sa propre identité. De plus, avec ce système, nous pouvons réaliser que les machines **ESSENCE** sont un élément décoratif et sont entièrement intégrées dans la conception de la pièce, obtenant un grand effet visuel.



Personalización con imagen
Customising Image
Personnalisation avec une image



Personalización con logotipo
Customising with logo
Personnalisation avec logo



Diseño conceptual
Conceptual design
Conception conceptuelle



SU INSTALACIÓN COMO NUEVA

YOUR BRAND NEW INSTALLATION

VOTRE INSTALLATION TOUTE NEUVE

El sistema de personalización **ESSENCE** permite renovar su instalación sin necesidad de cambiar las máquinas. Cambiando el diseño de las carcasas conseguirá renovar la sala de una forma cómoda, rápida y con una inversión mínima.

The **ESSENCE** customization system allows you to renew your installation without having to change machines. By changing the design of the case, you will be able to renew the room in a comfortable, fast way and with a minimum investment.

Le système de personnalisation **ESSENCE** vous permet de renouveler votre installation sans changer vos machines. En modifiant l'image du boîtier vous pourrez renouveler la salle de manière facile, rapide et avec un investissement minimum.

SALTER ofrece la posibilidad de personalizar la tapicería con la imagen corporativa o logotipo del cliente mediante un sistema de grabado por alta frecuencia que garantiza un perfecto acabado y durabilidad.

SALTER offers the possibility to customize the upholstery with the corporate image or the customer logo through a system of engraving by high frequency that guarantees a perfect finish and durability.

SALTER offre la possibilité de personnaliser la sellerie avec l'image corporative ou le logo de l'entreprise ou client a travers un système de gravure par haute fréquence qui garantit une finition et durabilité parfaites.



MÁQUINAS DE FUERZA • STRENGTH MACHINES • MACHINES DE MUSCULATION

■ Tronco superior - Upper body - Tronc supérieur ■ Zona media - Middle body - Tronc



M-2040
 Press horizontal de pecho
 Horizontal chest press
 Presse pectoraux horizontale

Dimensiones
 Dimensions
 116x169x157 cm



M-2084
 Contractora pecho
 Pec Fly
 Pec Fly

Dimensiones
 Dimensions
 86x168x157 cm

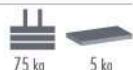

M-2043 DUAL
 Press de pecho / Press de hombros
 Chest press / Shoulder press
 Presse pectoraux / Presse d'épaules

Dimensiones
 Dimensions
 173x147x157 cm



M-2076
 Press de hombros
 Shoulder press
 Presse d'épaules

Dimensiones
 Dimensions
 127x147x157 cm



M-2020
 Flexión de bíceps
 Biceps curl
 Flexion des biceps

Dimensiones
 Dimensions
 112x101x157 cm



M-2096
 Tríceps
 Triceps
 Triceps

Dimensiones
 Dimensions
 109x103x157 cm



M-2023 DUAL
 Bíceps / Tríceps
 Biceps / Triceps
 Biceps / Triceps

Dimensiones
 Dimensions
 116x101x157 cm



M-2077
 Elevaciones laterales de hombro
 Lateral raise
 Elevations laterales épaules

Dimensiones
 Dimensions
 95x127x157 cm





M-2085 ■ DUAL
Contractora de pecho / Deltoides posterior
Pec Fly / Rear delt.
Pec Fly / Deltoïde arrière

Dimensiones
Dimensions
99 x160x207 cm

75 kg 5 kg



M-2098 ■
Dorsal vertical
Pulldown
Pulldown

Dimensiones
Dimensions
137 x162x183 cm

100 kg 5 kg



M-2088 ■ DUAL
Dominadas / Fondos asistidos
Dip / Chin assist
Dip / Chin assisté

Dimensiones
Dimensions
130 x138x216 cm

75 kg 5 kg



M-2041 ■
Remo sentado
Seated row
Rameur assis

Dimensiones
Dimensions
145 x103x157 cm

100 kg 5 kg



M-2049 ■
Lumbar
Lumbar
Lombaire

Dimensiones
Dimensions
107 x100x157 cm

75 kg 5 kg



M-2047 ■
Abdominal
Abdominal
Abdominal

Dimensiones
Dimensions
107 x100x157 cm

75 kg 5 kg



M-2048 ■ DUAL
Abdominal / Lumbar
Abdominal / Lumbar
Abdominal / Lombaire

Dimensiones
Dimensions
107 x100x157 cm

75 kg 5 kg



M-2046 ■
Giro de cintura
Rotary
Rotary torso

Dimensiones
Dimensions
141 x109x157 cm

75 kg 5 kg

MÁQUINAS DE FUERZA • STRENGTH MACHINES • MACHINES DE MUSCULATION

■ Tronco inferior - Lower body - Jambes

■ Zona media - Middle body - Tronc



M-2027
Flexión de piernas
Leg curl
Flexion des jambes

Dimensiones
Dimensions
152x102x157 cm



M-2026
Extensión de piernas
Leg extension
Extension des jambes

Dimensiones
Dimensions
101x103x157 cm



M-2029
Flexión de piernas sentado
Seated leg curl
Flexion des jambes assis

Dimensiones
Dimensions
101x103x157 cm



M-2082 DUAL
Extensión / Flexión de piernas
Leg extension / Leg curl
Extension / Flexion des jambes

Dimensiones
Dimensions
134x103x157 cm



12



M-2028
Femoral de pie
Kneeling leg curl
Flexion des jambes à genoux

Dimensiones
Dimensions
112x142x157 cm

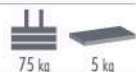

M-2019 DUAL
Sentadilla / Gemelo de pie
Squat / Standing calf
Squat / Mollets debout

Dimensiones
Dimensions
133x131x164 cm



M-2087
Prensa de piernas
Leg press
Presse des jambes

Dimensiones
Dimensions
210x104x157 cm

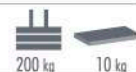

M-2018
Gemelo sentado
Seated calf
Extensions des mollets assis

Dimensiones
Dimensions
145x104x157 cm





M-2031 ■
Abductores
Abductors
Abducteurs

Dimensiones
Dimensions
133x133x157 cm

 75 kg
  5 kg

M-2025 ■
Glúteos
Gluteus
Fessiers

Dimensiones
Dimensions
129x103x157 cm

 100 kg
  5 kg

M-2032 ■
Aductores
Adductors
Adducteurs

Dimensiones
Dimensions
133x175x157 cm

 75 kg
  5 kg



M-2039 DUAL ■
Abductor / Aductor / Glúteos
Abductor / Adductor / Gluteus
Abducteur / Adducteur / Fessiers

Dimensiones
Dimensions
116x92x157 cm

 50 kg
  2,5 kg

M-2083 DUAL ■
Abductor / Aductor
Abductor / Adductor
Abducteur / Adducteur

Dimensiones
Dimensions
133x175x157 cm

 75 kg
  5 kg

Las máquinas **ESSENCE** incluyen un pictograma descriptivo del ejercicio que incluye, además, un código QR con acceso directo al video descriptivo del ejercicio y ajustes de la máquina.

The **ESSENCE** machines include a descriptive pictogram of the exercise that also includes a QR code that links to video showing how to do the exercise and how to set the machine.

Les machines **ESSENCE** incluent un pictogramme descriptif de l'exercice qui comprend également un code QR qui permet de visualiser la vidéo descriptif du exercice et les régulations de la machine.



Multipoleas

MULTIPLE PULLEYS · POULIES MULTIPLES





 **M-2093 DUAL**
Polea alta / Polea baja
High pulley / Low pulley
Poulie haute / Poulie basse

Dimensiones
Dimensions
198x69x221 cm

 
100 kg 5 kg



 **M-2091**
Polea alta
High pulley
Poulie haute

Dimensiones
Dimensions
132x119x237 cm

 
100 kg 5 kg



 **M-2092**
Polea baja
Low pulley
Poulie basse

Dimensiones
Dimensions
206x69x221 cm

 
100 kg 5 kg

■ **MULTIPOLEAS • MULTIPLE PULLEYS • POULIES MULTIPLES**



M-2090/1

Barra unión
Linkage bar
Barre d'union



M-2090

Poleas cruzadas, 3 estaciones
Cross-over, 3 station crossover
Poulie vis à vis, 3 stations



Dimensiones
Dimensions
374x69x224 cm



M-2097

Polea regulable
Adjustable pulley
Poulie réglable

Dimensiones
Dimensions
82x69x221 cm

 50 kg  2,5 kg

3 ESTACIONES · STATIONS · STATIONS		
2 Poleas regulables · 2 Adjustable pulleys · 2 Poulies réglables	2,5	50+50
Barra dominada · Dip/Chin bar · Dip/Chin barre	-	-

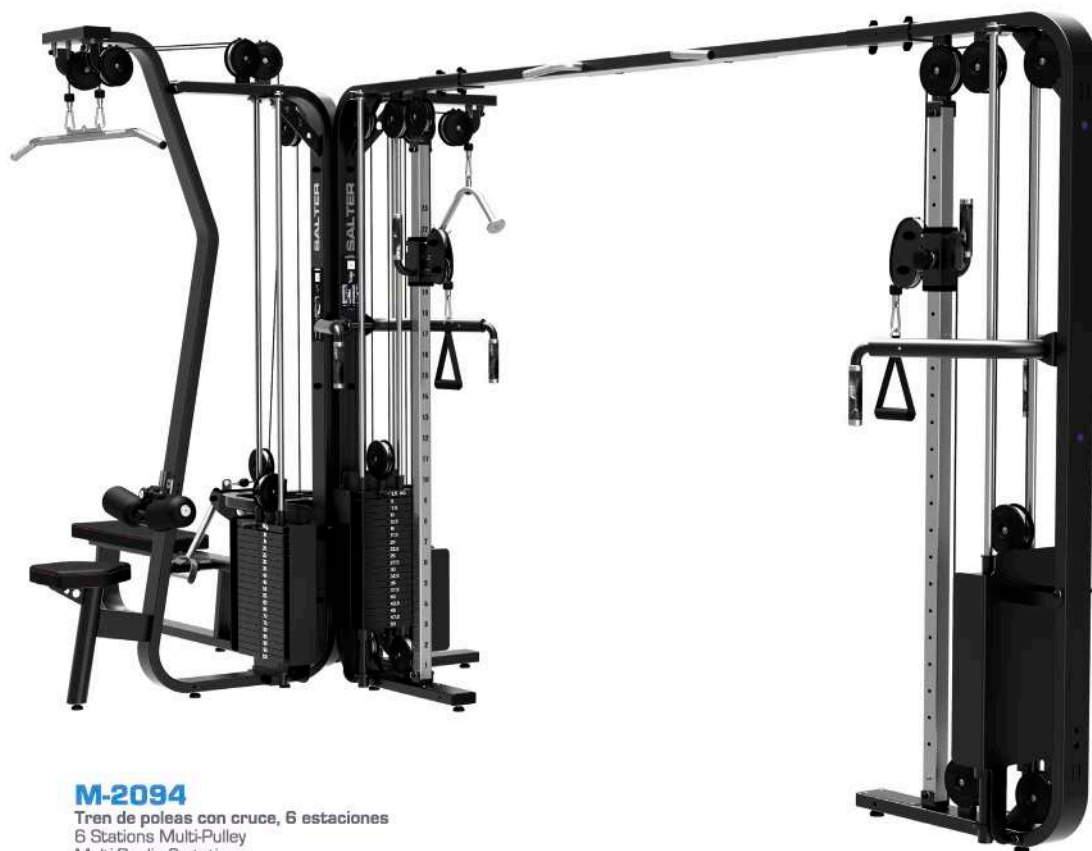

M-2094

Tren de poleas con cruce, 6 estaciones
6 Stations Multi-Pulley
Multi-Poulie 6 stations



Dimensiones
Dimensions
582x175x237 cm



M-2089

Tren de poleas, 4 estaciones
4 Stations Multi-Pulley
Multi-Poulie 4 stations

Dimensiones
Dimensions
291x175x237 cm

6 ESTACIONES · STATIONS · STATIONS		
Polea alta · High pulley · Poulie haute	5	100
Polea baja · Low pulley · Poulie basse	5	100
Polea tríceps · Triceps pulley · Poulie triceps	5	75
2 Poleas regulables · 2 Adjustable pulleys · 2 Poulies réglables	2,5	50+50
Barra dominada · Dip/Chin bar · Dip/Chin barre	-	-

4 ESTACIONES · STATIONS · STATIONS		
Polea alta · High pulleys · Poulies hautes	5	100
Poleas baja · Low pulleys · Poulies basses	5	100
Poleas tríceps · Triceps pulleys · Poulies triceps	5	75
Polea regulable · Adjustable pulleys · Poulies réglables	2,5	50

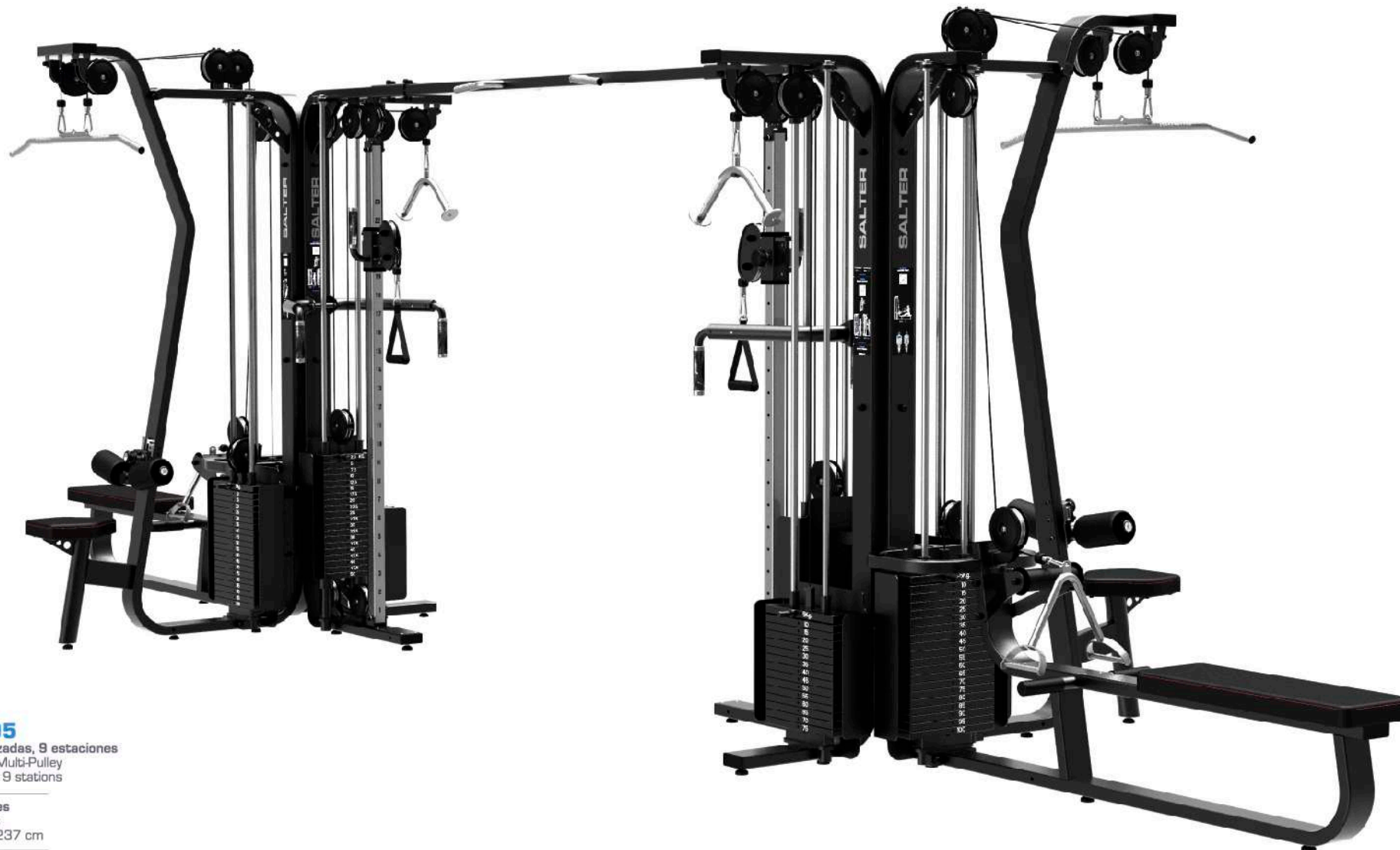

MULTIPOLEAS • MULTIPLE PULLEYS • POULIES MULTIPLES



M-2095

Poleas cruzadas, 9 estaciones
9 Stations Multi-Pulley
Multi-Poulie 9 stations

Dimensiones
Dimensions
790x230x237 cm

9 ESTACIONES · STATIONS · STATIONS		
2 Poleas altas · 2 High pulleys · 2 Poulies hautes	5	100+100
2 Poleas bajas · 2 Low pulleys · 2 Poulies basses	5	100+100
2 Poleas tríceps · 2 Triceps pulleys · 2 Poulies tríceps	5	75+75
2 Poleas regulables · 2 Adjustable pulleys · 2 Poulies réglables	2,5	50+50
Barra dominada · Dip/Chin bar · Dip/Chin barre	-	-



Escanear QR para acceder al video • Scan QR to access the video • Scan QR pour accéder à la vidéo



Polea alta
High pulley
Poulie haute



Polea baja
Low pulley
Poulie basse



Polea tríceps
Triceps pulley
Poulie tríceps



Polea regulable
Adjustable pulley
Poulie réglable

4 ESTACIONES · STATIONS · STATIONS		
Polea alta · High pulley · Poulie haute	5	75
Extensión de piernas / Press de hombro · Leg extension / Shoulder press · Extension de jambes / Presse d'épaules	5	75
Press de pecho / Remo dorsal · Chest press / Seated row / Press pectoraux / Rameur assis	5	75
Polea regulable · Adjustable pulley · Poulie réglable	2,5	50



Escanear QR para acceder al video
Scan QR to access the video
Scan QR pour accéder à la vidéo



Polea alta • High pulley • Poulie haute



Extensión de piernas / Press hombro
Leg extension / Shoulder press
Extension de jambes / Presse d'épaules



Press de pecho / Remo dorsal
Chest press / Seated row
Extension de jambes / Presse d'épaules



Polea regulable • Adjustable pulley • Poulie réglable

M-2021

Multifunción 4x4
Multifunction 4x4
Multifonction 4x4

Dimensiones
Dimensions
238x241x221 cm



MANILLARES • HANDLEBARS • POIGNÉES

Los agarres y manillares permiten realizar múltiples ejercicios aumentando las posibilidades de trabajo con poleas y logrando un máximo rendimiento en el entreno. **SALTER** cuenta con una amplia línea de manillares para un trabajo específico en función de los objetivos que se quieran alcanzar.

Grips and handlebars allow multiple exercises increasing the possibilities of working with pulleys and achieving maximum performance in training. **SALTER** has a wide range of handlebars for a specific work depending on the objectives you want to achieve.

Les poignées et guidons permettent réaliser des multiples exercices augmentant les possibilités de travailler avec les poulies et réussir une performance maximale à l'entraînement. **SALTER** dispose d'une large gamme de guidons pour un travail spécifique en fonction des objectifs que vous souhaitez atteindre.



M-7090
Empuñadura polea
Pulley grip
Poignée poulie



M-7120
Manillar curvo tríceps
Tricep curved handlebar
Poignée courbe tríceps



M-714
Cuerda tríceps
Triceps rope
Corde tríceps



P-313
Tobillera polea
Ankle pulley
Chevillère



M-7095
Manillar remo dorsal
Dorsal row handlebar
Poignée rameur dorsal



M-7155
Manillar dorsal doble agarre
Dorsal handlebar with double grip
Poignée dorsal double



M-7101
Manillar remo dorsal
Dorsal rowing handlebar
Guidon d'aviron dorsal



M-7130
Manillar rotativo
Rotary handlebar
Poignée rotatif



M-004
Chaleco anillas
Ring vest
Veste d'anneaux



M-7140
Manillar dorsal
Dorsal handlebar
Poignée dorsal



Entrenamiento funcional

FUNCTIONAL TRAINING · ENTRAÎNEMENT FONCTIONNEL





SALTER propone un sistema de configuración modular que permite configurar la estructura funcional que mejor se adapta a las necesidades de cada instalación y al espacio disponible. Con el sistema modular **SALTER** la estructura funcional puede ir creciendo a medida que se precise. Añadiendo más módulos y combinando los distintos accesorios disponibles podemos adaptar la estructura a las necesidades de cada momento ofreciendo así mayores posibilidades de entreno a los usuarios.

SALTER proposes a modular configuration system that allows configuring the functional structure that best suits the needs of each installation and according to the available space. With **SALTER**'s modular system, the functional structure can grow as needed. By adding more modules and combining the different accessories available we can adapt the structure to the needs of each moment and thus offer more training possibilities to users.

SALTER propose un système de configuration modulaire qui permet de configurer la structure fonctionnelle la mieux adaptée aux besoins de chaque installation et à l'espace disponible. Avec ce système modulaire **SALTER**, la structure fonctionnelle peut évoluer selon les besoins. En ajoutant plus de modules et en combinant les différents accessoires disponibles, nous pouvons adapter la structure aux besoins de chaque instant et offrir ainsi de plus grandes possibilités d'entraînement aux utilisateurs.



F-1022

Estructura funcional, módulo básico
Functional rack, basic unit
Rack fonctionnel, unité de base

Dimensiones
Dimensions
131x116x242 cm

ESTRUCTURA EN ISLA · MULTIPLE RACK · ESTRUCTURE D' ÎLE



ESTRUCTURA PUENTE · BRIDGE RACK · STRUCTURE DU PONT



ESTRUCTURA MURAL · WALL RACK · STRUCTURE MURALE



ESTRUCTURA COMBINADA · COMBINED RACK · STRUCTURE COMBINÉE



ACCESORIOS PARA ESTRUCTURAS FUNCIONALES • FUNCTIONAL RACK ACCESSORIES

ACCESSOIRES POUR ESTRUCTURES FONCTIONNELSLS

F-1020/AB-128		Anclaje giratorio para barra Ø30 mm Ø30 mm rotatory bar fixing Ancrage pivotant pour barre de 30 mm	F-1021/BK		Bandeja almacenaje Storage rack Plateau de stockage
F-1020/AB-150		Anclaje giratorio para barra Ø50 mm Ø50 mm rotatory bar fixing Ancrage pivotant pour barre de Ø50 mm	F-1021/BOX		Soporte para saco boxeo Boxing bag fixation Support pour sac de frappe
F-1020/BE		Anclajes para bandas elásticas (2 unidades) Band rack (2 units) Ancrages pour bandes élastiques (2 unités)	F-1021/ES		Escalera unión Stair linkage Échelle d'union
F-1020/FC		Fijación cuerda de combate Combat rope fixation Attachement pour corde de combat	F-1021/GU		Grupo unión Linkage Tube union
F-1020/MA		Paralelas para fondos Dip/chin handlebar Support pour chin/dip	F-1021/SB		Soportes para barra (2 unidades) Bar support (2 pcs) Support pour barre (2 unités)
F-1020/PL		Diana Dartboard Diane	F-1021/SOP		Soportes de seguridad para barra (2 unidades) Security bar support (2 pcs) Ensemble de supports de sécurité pour barre (2 unités)
F-1020/PT		Plataforma de saltos Jumpling platform Plateforme de saut	F-1021/SP		Soportes sujeción pared (2 unidades) Wall fixing (2 pcs) Jeu de supports de fixation murale (2 unités)
F-1022/SD		Soporte para discos Ø30 mm Ø30 mm plate rack Support pour disques de Ø30 mm	F-1021/SR		Soportes sujeción regulables (2 unidades) Adjustable supports (2 pcs) Supports de fixation réglables (2 unités)
F-1022/SD/50		Soporte para discos Ø50 mm Ø50 mm plate rack Support pour disques de Ø50 mm	F-1021/TAR		Tarima Platform Plateforme
F-1021/BH		Barras horizontales Horizontal bars Barres horizontales	F-1021/UM		Tubo unión Linkage Barre d'union



Máquinas de peso libre

FREE WEIGHT MACHINES • MACHINES À POIDS LIBRE



MÁQUINAS DE PESO LIBRE

FREE WEIGHT MACHINES

MACHINES À POIDS LIBRE



M-1541 · M-1541/50

Remo sentado
Seated row
Rameur assis

Dimensiones
Dimensions
141x142x129 cm

REF.	Discos • Plates • Disques
M-1541	Ø 30 mm
M-1541/50	Ø 50 mm

Las máquinas de peso libre se suministran sin discos.

Free weight machines are supplied without plates.

Les machines de poids libre sont fournies sans disques.



Estas máquinas de peso libre han sido diseñadas biomecánicamente para ofrecer una máxima funcionalidad y rendimiento. El arco de movimiento convergente/divergente imita el trabajo con peso libre. Los brazos de palanca independientes permiten un trabajo unilateral. Además, su estructura sólida y resistente permite entrenar a nivel intenso incluso con cargas elevadas.

These free weight machines have been biomechanically designed to offer maximum functionality and performance. The convergent / divergent arc of movement imitates free weight workout. Independent lever arms allow unilateral work. Besides, its solid and resistant structure allows training at an intense level even with heavy loads.

Ces machines à poids libre ont été conçues biomécaniquement pour offrir une fonctionnalité et une performance maximale. L'arc de mouvement convergent / divergent imite le travail à poids libre. Les bras de levier indépendants permettent un travail unilatéral. En plus, sa structure solide et résistante permet un entraînement à un niveau intense même avec des charges élevées.



M-1526 · M-1526/50

Extensión de piernas
Leg extension
Extension de jambes

Dimensiones
Dimensions
104x122x130 cm

REF.	Discos • Plates • Disques
M-1526	Ø 30 mm
M-1526/50	Ø 50 mm



M-1540 · M-1540/50

Press de pecho
Chest press
Presse pectorale

Dimensiones
Dimensions
128x196x172 cm

REF.	Discos • Plates • Disques
M-1540	Ø 30 mm
M-1540/50	Ø 50 mm



M-1543 · M-1543/50

Press inclinado de pecho
Inclined chest press
Presse pectorale inclinée

Dimensiones
Dimensions
104x211x170 cm

REF.	Discos • Plates • Disques
M-1543	Ø 30 mm
M-1543/50	Ø 50 mm



M-1576 · M-1576/50

Press de hombros
Shoulder press
Presse d'épaules

Dimensiones
Dimensions
133x160x138 cm

REF.	Discos • Plates • Disques
M-1576	Ø 30 mm
M-1576/50	Ø 50 mm



M-1527 · M-1527/50

Flexión de piernas
Leg curl
Flexion de jambes

Dimensiones
Dimensions
107x152x69 cm

REF.	Discos · Plates · Disques
M-1527	Ø 30 mm
M-1527/50	Ø 50 mm



M-1591 · M-1591/50

Dorsal vertical
Lat Pulldown
Dorsal verticale

Dimensiones
Dimensions
175x118x195 cm

REF.	Discos · Plates · Disques
M-1591	Ø 30 mm
M-1591/50	Ø 50 mm



M-1525 · M-1525/50

Glúteos
Gluteus
Fessiers

Dimensiones
Dimensions
130x155x114 cm

REF.	Discos · Plates · Disques
M-1525	Ø 30 mm
M-1525/50	Ø 50 mm



M-1598 · M-1598/50

Remo en punta
T-Bar row
Rameur T-Bar

Dimensiones
Dimensions
180x164x125 cm

REF.	Discos · Plates · Disques
M-1598	Ø 30 mm
M-1598/50	Ø 50 mm



M-1518 · M-1518/50

Gemelo sentado
Seated Calf
Extensions des mollets assis

Dimensiones
Dimensions
147x128x82 cm

REF.	Discos · Plates · Disques
M-1518	Ø 30 mm
M-1518/50	Ø 50 mm



M-1584 · M-1584/50

Contractora de pecho
Pec fly
Pec fly

Dimensiones
Dimensions
159x174x106 cm

REF.	Discos · Plates · Disques
M-1584	Ø 30 mm
M-1584/50	Ø 50 mm

PRENSA INCLINADA

LEG PRESS

PRESSE À CUISSSES



M-1099 · M-1099/50

Prensa inclinada
Leg press
Presse à cuisses

Dimensiones
Dimensions
247x128x144 cm

REF.	Discos • Plates • Disques
M-1099	Ø 30 mm
M-1099/50	Ø 50 mm



La prensa inclinada se suministra sin discos
The leg press is supplied whitout plates
La presse à cuisses est fournie sans disques

PRENSA DE PIERNAS / JACA

LEG PRESS / HACK-SQUAT

PRESSE À JAMBES / HACK-SQUAT



M-1086 · M-1086/50 DUAL

Prensa de piernas / Jaca
Leg Press / Hack-squat
Presse jambes / Hack-squat

Dimensiones
Dimensions
270x120x170 cm

REF.	Discos · Plates · Disques
M-1086	Ø 30 mm
M-1086/50	Ø 50 mm



M-1033 · M-1033/50

Multipower
Multipower
Multipower

Dimensiones
Dimensions
133x192x227 cm

REF.	Discos · Plates · Disques
M-1033	Ø 30 mm
M-1033/50	Ø 50 mm



F-1021 · F-1021/50

Jaula de fuerza Mod. Half
Half power cage
Cage de musculation

Dimensiones
Dimensions
179x116x240 cm

REF.	Discos · Plates · Disques
F-1021	Ø 30 mm
F-1021/50	Ø 50 mm



F-1020 · F-1020/50

Jaula de fuerza
Power cage
Cage de musculation

Dimensiones
Dimensions
202x182x240 cm

REF.	Discos · Plates · Disques
F-1020	Ø 30 mm
F-1020/50	Ø 50 mm

ACCESORIOS PESOS LIBRES

FREE WEIGHT ACCESSORIES

ACCESSOIRES POIDS LIBRE



Discos de caucho Ø30 mm
Ø30 mm Rubber discs
Disques caoutchouc Ø30 mm

REF.	kg	Ø
C-361	1,25	30 mm
C-362	2,5	30 mm
C-363	5	30 mm
C-364	10	30 mm
C-365	15	30 mm
C-366	20	30 mm
C-367	25	30 mm



Barras alzamiento con fijaciones Ø30 mm
Ø30 mm Barbell bars with fixations
Barres avec fixations Ø30 mm

REF.	kg	Ø
B-3012	120	30 mm
B-3015	150	30 mm
B-3018	180	30 mm
B-3020	200	30 mm
B-3022	220	30 mm
B-3036	biceps	30 mm



Fijaciones (2 unidades)
Fixations (2 units)
Fixations (2 unités)

REF.	Ø
B-2227	30 mm
D-5027	50 mm



Discos de caucho Ø50 mm
Ø50 mm Rubber discs
Disques caoutchouc Ø50 mm

REF.	kg	Ø
D-2071	1,25	50 mm
D-2072	2,5	50 mm
D-2073	5	50 mm
D-2074	10	50 mm
D-2075	15	50 mm
D-2076	20	50 mm
D-2077	25	50 mm



Barras alzamiento con fijaciones Ø50 mm
Ø50 mm Barbell bars with fixations
Barres avec fixations Ø50 mm

REF.	kg	Ø
D-5012	120	50 mm
D-5015	150	50 mm
D-5018	180	50 mm
D-5020	200	50 mm
D-5022	220	50 mm
D-5036	biceps	50 mm



Fijaciones Ø50 mm (2 un.)
Ø50 mm fixations (2 units)
Fixations Ø50 mm (2 unités)

REF.	Ø
D-5000	50 mm





Bancos

BENCHES • BANCS





F-1053

Banco plano
Flat bench
Banc horizontal

Dimensiones
Dimensions
117x44x46 cm



F-1057

Banco con inclinación/declinación regulables
Incline/decline adjustable bench
Banc réglable inclinaison/déclinaison

Dimensiones
Dimensions
120x43x46 cm



F-5561

Banco multifunción
Multifunctional bench
Banc multifonction

Dimensiones
Dimensions
160x60x153 cm



F-1085

Banco press inclinado
Inclined press bench
Banc presse incline

Dimensiones
Dimensions
162x121x131 cm

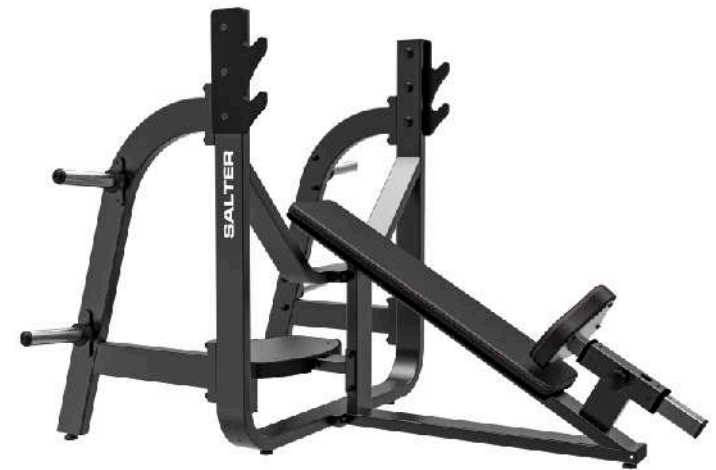

F-1085/50

Banco press inclinado con soporte discos 50 mm
Inclined press bench with 50 mm plate racks
Banc presse incliné avec supports pour disques 50 mm

Dimensiones
Dimensions
188x121x121 cm



F-1025

Banco press horizontal
Horizontal press bench
Banc presse horizontal

Dimensiones
Dimensions
172x121x115 cm



F-1025/50

Banco press horizontal con soporte discos 50 mm
Horizontal press bench with 50 mm plate racks
Banc presse horizontal avec supports pour disques 50 mm

Dimensiones
Dimensions
198x121x116 cm



F-1077

Banco press declinado
Declined press bench
Banc presse decliné

Dimensiones
Dimensions
155x121x98 cm



F-1076

Banco press hombros
Shoulder press bench
Banc presse d'épaule

Dimensiones
Dimensions
101x121x158 cm



F-1076/50

Banco press hombro con soporte discos 50 mm
Shoulder press bench with 50 mm plate racks
Banc presse d'épaule avec supports pour disques 50 mm

Dimensiones
Dimensions
127x172x158 cm



F-1077/50

Banco press declinado con soporte discos 50 mm
Declined press bench with 50 mm plate racks
Banc presse decliné avec supports pour disques 50 mm

Dimensiones
Dimensions
216x172x98 cm



F-1062
 Banco abdominales
 Abdominal bench
 Banc abdominaux

Dimensiones
 Dimensions
 144x58x108 cm



F-1070
 Banco bíceps
 Scott bench
 Banc biceps

Dimensiones
 Dimensions
 95x75x100 cm



M-1017
 Banco hiperextensiones
 Hyperextension bench
 Banc à lombaire

Dimensiones
 Dimensions
 129x74x91 cm



M-2016
 Banco estiramientos
 Stretching bench
 Banc d'étirement

Dimensiones
 Dimensions
 121x52x132 cm



M-2063 ■ ■ ■
 Fondos / Abdominales / Dominadas
 Dips / Chin bar / Abdominals
 Fonds / Dominiaux / Abdominaux

Dimensiones
 Dimensions
 103x108x235 cm



M-2062 ■ ■ ■
 Fondos / Abdominales
 Dips / Abdominals
 Fonds / Abdominaux

Dimensiones
 Dimensions
 102x66x162 cm



F-245
 Soportes sentadilla
 Squat rack
 Squat rack

Dimensiones
 Dimensions
 41x41x181 cm

BANCO PULL • PULL BENCH • BANC PULL

SALTER en colaboración con profesionales del remo ha desarrollado el banco Pull para dar respuesta a las necesidades de estos usuarios. El banco Pull permite un trabajo muy específico que ha demostrado aumenta el rendimiento de estos profesionales. Por este motivo, muchos equipos profesionales de remo incluyen el banco Pull en su programa diario de entrenamiento.

SALTER in collaboration with rowing professionals has developed the Pull bench to respond to the needs of these users. The Pull bench allows a very specific workout that has been proved it permits to improve the performance of these professionals. For this reason, many professional rowing teams include the Pull bench in their daily training program.

SALTER en collaboration avec des professionnels d'aviron a développé le banc Pull pour répondre aux besoins de ces utilisateurs. Le banc Pull permet des travaux très spécifiques dont il a été démontré qu'ils augmentent les performances de ces professionnels. Pour cette raison, de nombreuses équipes professionnelles d'aviron incluent le banc Pull dans leur programme d'entraînement quotidien.



F-5580

Banco Pull
Pull bench
Banc Pull

Dimensiones
Dimensions
214x62x96 cm

El banco dispone de un mando que permite ajustar la altura de la camilla de 71 a 96 cm para conseguir la distancia óptima de trabajo.

The bench has a control that allows adjusting the height of the stretcher from 71 to 96 cm to achieve the optimal working distance.

Le banc dispose d'un contrôle qui permet d'ajuster la hauteur de la civière de 71 à 96 cm pour atteindre la distance de travail optimale.

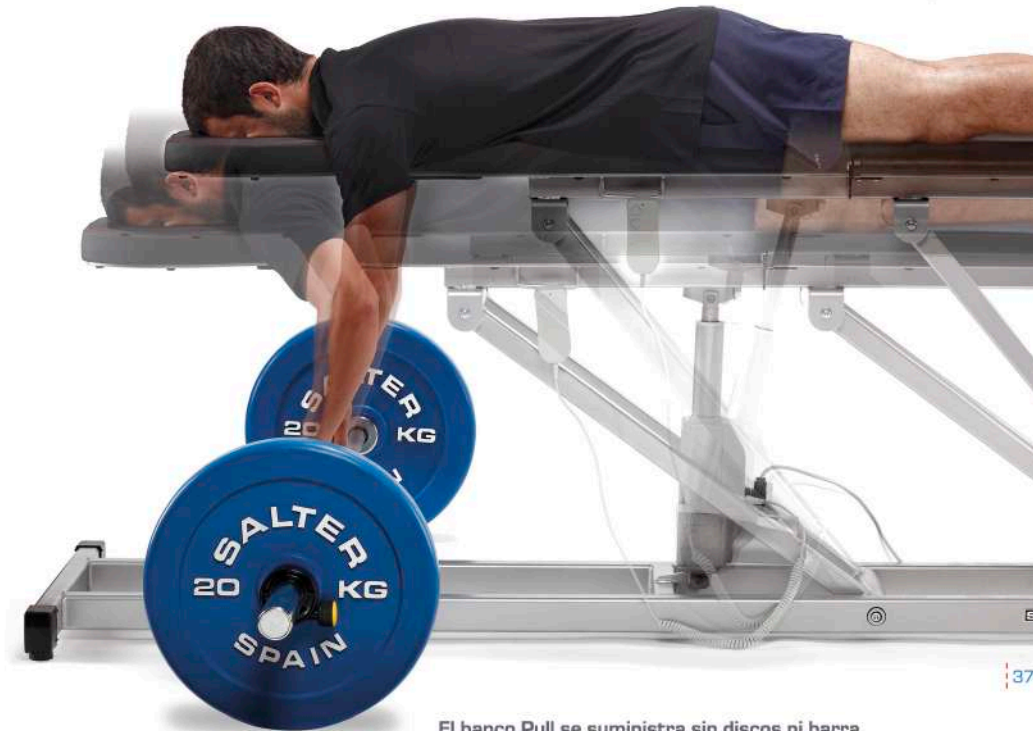

El banco Pull se suministra sin discos ni barra.
The Pull bench is supplied without plates nor barbell.
Le banc Pull est fourni sans disques et barre.





Soportes y Mancuernas

RACKS AND DUMBBELLS • SUPPORTS ET HALTÈRES





MANCUERNAS TPU
TPU DUMBBELLS
HALTÈRES TPU

REF.	Peso kg • Weight • Poids
C-0010	1 kg
C-0020	2 kg
C-0025	2,5 kg
C-0030	3 kg
C-0040	4 kg
C-0050	5 kg
C-0060	6 kg
C-0070	7 kg
C-0075	7,5 kg
C-0080	8 kg
C-0090	9 kg
C-0100	10 kg
C-0125	12,5 kg
C-0150	15 kg
C-0175	17,5 kg
C-0200	20 kg
C-0225	22,5 kg
C-0250	25 kg
C-0275	27,5 kg
C-0300	30 kg
C-0325	32,5 kg
C-0350	35 kg
C-0375	37,5 kg
C-0400	40 kg
C-0425	42,5 kg
C-0450	45 kg
C-0475	47,5 kg
C-0500	50 kg



I-1736

Soporte para 6 juegos de mancuernas TPU
Rack for 6 sets of TPU dumbbells
Support pour 6 jeux d'haltères TPU

Dimensiones
Dimensions
147x60x89 cm

El soporte I-1736 se suministra sin pesas.
The rack I-1736 is supplied without dumbbells.
Le support I-1736 est fourni sans haltères.

Las pesas se suministran por unidades
Dumbbells are supplied per units
Les haltères sont livrées par unités



I-1734

Soporte para 10 juegos de mancuernas TPU de 1 a 10 kg
 Rack for 10 sets of TPU dumbbells from 1 to 10 kg
 Support pour 10 jeux d'haltères TPU de 1 à 10 kg

Dimensiones
 Dimensions
 57x76x125 cm



PESAS CAUCHO RUBBER DUMBBELLS HALTÈRES CAOUTCHOUC

REF.	Peso • Weight • Poids
PT-2801	1 kg
PT-2802	2 kg
PT-2803	3 kg
PT-2804	4 kg
PT-2805	5 kg
PT-2806	6 kg
PT-2808	8 kg
PT-2810	10 kg



Las pesas se suministran por unidades
 Dumbbells are supplied per units
 Les haltères sont livrées par unités



I-209

Soporte vertical para 4 juegos de mancuernas caucho
 Rack for 4 sets of rubber dumbbells
 Support pour 4 jeux d'haltères caoutchouc

Dimensiones
 Dimensions
 30x22x64 cm



I-219

Soporte vertical de madera para 4 juegos de mancuernas caucho
 Wood rack for for 4 sets of rubber dumbbells
 Support en bois pour 4 jeux d'haltères caoutchouc

Dimensiones
 Dimensions
 25x25x69 cm

SOPORTES
RACKS
SUPPORTS



I-1708

Soporte para discos, barras y fijaciones
Rack for plates, barbells and safety collars
Support pour disques, barres et fixations

Dimensiones
Dimensions
116x63x146 cm



I-1728

I-1728/50

Soporte para discos y barras
Plate and bar rack
Support pour disques et barres

Dimensiones
Dimensions
110x69x150 cm



REF.	Discos • Platas • Disques
I-1728	Ø 30 mm
I-1728/50	Ø 50 mm



I-1730/50

Soporte para barras alzamiento Ø50 mm (barras no incluidas)
Capacidad para 9 barras.
Rack for Ø50 mm barbells (barbells are not included)
Capacity 9 barbells.
Support pour barres Ø50 mm (les barres ne sont pas incluses)
Capacité: 9 barres

Dimensiones Dimensions
71x71x23 cm



Y-5445

Soportes fijación mural para colchonetas
Wall fixing racks for mats
Supports de fixation murale pour tapis

Dimensiones Dimensions
10x6x20 cm



Y-5460

Colchoneta Fitness
Fitness mat
Tapis Fitness

Dimensiones Dimensions
140x60x1,5 cm



Máquinas Línea CIRCUIT

CIRCUIT LINE MACHINES · MACHINES LIGNE CIRCUIT

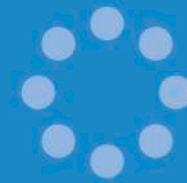

MÁQUINAS CIRCUIT

CIRCUIT LINE MACHINES

MACHINES LIGNE CIRCUIT



M-1126

Cuadriceps / Femoral
Leg curl / Leg extension
Flexion / Extension des jambes

Dimensiones
Dimensions
101x77x120 cm

La línea **CIRCUIT** se identifica claramente por el sistema hidráulico de resistencia que incorpora que permite ejercitar la musculatura agonista y antagonista en un mismo movimiento de manera que el equilibrio de las estructuras musculares, que afectan a las principales articulaciones del cuerpo, está garantizado.

Por esta razón, la línea **CIRCUIT** está especialmente indicada en procesos de rehabilitación y readaptación de lesiones, sin embargo, su gran versatilidad de uso convierte las máquinas **CIRCUIT** en una gran opción para gimnasios, centros deportivos, hoteles, SPA y residencias particulares.

The **CIRCUIT** line is clearly identified by its resistance hydraulic system that allows exercising the agonist and antagonist muscles in the same movement so that the balance of the muscular structures, which affect the main joints of the body, is guaranteed.

For this reason, the **CIRCUIT** line is especially indicated in injury rehabilitation and rehabilitation processes, however, its great versatility of use makes **CIRCUIT** machines a great option for gyms, sports centers, hotels, SPAs and private residences.

La ligne **CIRCUIT** est clairement identifiée par le système hydraulique de résistance qu'elle incorpore qui permet d'exercer les muscles agonistes et antagonistes dans le même mouvement afin que l'équilibre des structures musculaires, qui affectent les principales articulations du corps, est garanti.

Pour cette raison, la ligne **CIRCUIT** est particulièrement indiquée dans les processus de rééducation et de rééducation des blessures, cependant, sa grande polyvalence d'utilisation fait des machines **CIRCUIT** une excellente option pour les gymnases, les centres sportifs, les hôtels, les SPA et les résidences privées.



M-1140
Press - Pull horizontal
Horizontal press - Pull
Pectoraux - Dorsaux

Dimensiones
Dimensions
83x73x120 cm



M-1147
Abdominal / Lumbar
Abdominal / Lumbar
Abdominal / Lombaire

Dimensiones
Dimensions
83x71x130 cm



M-1176
Press - Pull vertical
Vertical press - Pull
Épaules - Dorsaux

Dimensiones
Dimensions
100x73x119 cm



M-1183
Abductores - Aductores
Abductors - Adductors
Abducteurs - Adducteurs

Dimensiones
Dimensions
119x59x120 cm



M-1184
Pectoral / Zona escapular
Pectoral / Scapular zone
Pectoraux / Zone scapulaire

Dimensiones
Dimensions
84x141x120 cm



M-1187
Prensa de piernas
Leg press
Press de jambes

Dimensiones
Dimensions
136x54x119 cm



M-1120
Bíceps - Tríceps
Biceps - Triceps
Biceps - Triceps

Dimensiones
Dimensions
118x51x87 cm



M-1185
Sentadilla
Hack Squat
Hack Squat

Dimensiones
Dimensions
143x78x121 cm



CIRCUITOS COMPLETOS

FULL CIRCUIT

CIRCUIT COMPLET

		M-1000	M-1001
M-1120		✓	✓
M-1126		✓	✓
M-1140		✓	✓
M-1147		✓	✓
M-1176		✓	✓
M-1183		✓	✓
M-1184		✓	✓
M-1185		✓	✓
M-1187		-	✓

PRESENCIA ON LINE

Contacto directo con el cliente

Descubra todos nuestros servicios en www.salter.es, donde, además de otros contenidos, están disponibles todos nuestros catálogos, fichas técnicas, vídeos de montaje y manuales de uso y mantenimiento de nuestros productos.

ON LINE PRESENCE

Direct contact with the customer

Discover all of our services on www.salter.es, where in addition to other content, all of our catalogues, technical datasheets, set up videos and usage and maintenance manuals for our products are available.

PRÉSENCE EN LIGNE

Contact direct avec le client

Découvrez tous nos services sur www.salter.es. Outre les contenus, vous pourrez y consulter nos catalogues, les fiches techniques, les notices d'utilisation et d'entretien de nos produits et les vidéos de montage.



www.salter.es





SALTER

The **essence** of fitness

DELEGACIÓN BARCELONA

T. 933 720 300
sport@salter.es

DELEGACIÓN MADRID

T. 915 017 908
saltermadrid@salter.es

DELEGACIÓN VALENCIA

T. 963 487 630
saltervalencia@salter.es

DEPARTAMENTO INTERNACIONAL

T. (+34) 934 700 055
internationalsales@salter.es

www.salter.es